

DH-HAC-B2A21-U-IL

2MP Smart Dual Light HDCVI Fixed-focal Bullet Camera



* In order to use the Smart Dual Light HDCVI camera, the firmware of XVR must be upgraded to V4.001.0000004.1.R.220323 or later version.

- Max. 30 fps@1080p.
- Smart Dual Light.
- 30 m illumination distance.
- 3.6 mm fixed lens (2.8 mm, 6 mm optional).
- CVI/CVBS/AHD/TVI switchable.
- IP67, 12 VDC.



Series Overview

The Cooper Series offers simple and highly cost-effective HDCVI solutions. It provides 24/7 reliable monitoring with high-quality image performance, saving cost on both material and labor force. It is also designed and built to the specific standards of Dahua.

Functions

Smart Dual Light

With its smart dual light mechanism, the camera automatically turns on the white light when Perimeter Protection/SMD Plus function of AI XVR detects a target in the rule area to capture clear, vivid images. When the target leaves the rule area, the camera automatically switches over from the white light to the IR light to significantly reduce light pollution.

Protection (IP67, Wide Voltage)

IP67: The camera passed a series of rigorous dust and immersion tests. Its enclosure is both dust-proof and waterproof, and can function normally while being immersed in 1 m deep water for up to 30 minutes. Wide voltage: The camera has $\pm 30\%$ input voltage tolerance (for some power supplies) and a wide voltage range, making it suitable for a variety of outdoor scenarios.

4 Signals over 1 Coaxial Cable

HDCVI technology supports 4 signals (video, audio*, data and power) which are simultaneously transmitted over a coaxial cable. Dual-way data transmission allows the HDCVI camera to interact with the XVR to perform various actions such as sending control signals and triggering alarms. HDCVI technology also supports PoC, which makes the camera easy and quick to install.

* Audio input is available for select HDCVI camera models.

Long Distance Transmission

HDCVI technology provides long distance transmission in real time without transmission loss. It supports transmission distances up to 700 m for 2-MP/5-MP/8-MP HD videos through coaxial cables, and up to 300 m through UTP cables. The results were obtained and verified through rigorous testing in Dahua's test laboratory.

Simplicity

HDCVI technology inherits the simplicity of traditional analog surveillance systems, making it a great mechanism for protecting your valuables. HDCVI can be upgraded from the traditional analog system without replacing the existing coaxial cabling. Its plug and play design enables it to produce high-definition videos during surveillance without the hassle of configuring a network.

Technical Specification

Camera

Image Sensor	2 MP CMOS
Max. Resolution	1920 (H) × 1080 (V)
Scanning System	Progressive
Electronic Shutter Speed	PAL: 1/25 s–1/100,000 s; NTSC: 1/30 s–1/100,000 s
Min. Illumination	0.02 lux@F2.0 (Color, 30 IRE); 0.002 lux@F2.0 (B/W, 30 IRE); 0 lux (Illuminator on)
S/N Ratio	>65 dB
Illumination Distance	IR: 30 m (98.43 ft); Warm light: 20 m (65.62 ft)
Illuminator On/Off Control	Auto;Manual
Illuminator Number	2 (Warm light);2 (IR light)
Angle Adjustment	Pan: 0°–360° Tilt: 0°–90° Rotation: 0°–360°

Lens

Lens Type	Fixed-focal																				
Lens Mount	M12																				
Focal Length	2.8 mm; 3.6 mm; 6 mm																				
Max. Aperture	F2.0																				
Field of View	2.8 mm: H: 100°; V: 54°; D: 117° 3.6 mm: H: 80°; V: 43°; D: 94° 6 mm: H: 43°; V: 24°; D: 50°																				
Iris Control	Fixed																				
Close Focus Distance	2.8 mm: 0.5 m (1.64 ft) 3.6 mm: 0.8 m (2.62 ft) 6 mm: 2.4 m (7.87 ft)																				
DORI Distance	<table border="1"> <thead> <tr> <th>Lens</th> <th>Detect</th> <th>Observe</th> <th>Recognize</th> <th>Identify</th> </tr> </thead> <tbody> <tr> <td>2.8 mm</td> <td>44.7 m (146.65 ft)</td> <td>17.9 m (58.73 ft)</td> <td>8.9 m (29.20 ft)</td> <td>4.5 m (14.76 ft)</td> </tr> <tr> <td>3.6 mm</td> <td>55.0 m (180.45 ft)</td> <td>22.0 m (72.18 ft)</td> <td>11.0 m (36.09 ft)</td> <td>5.5 m (18.04 ft)</td> </tr> <tr> <td>6 mm</td> <td>102.9 m (337.60 ft)</td> <td>41.1 m (134.84 ft)</td> <td>20.6 m (67.59 ft)</td> <td>10.3 m (33.79 ft)</td> </tr> </tbody> </table>	Lens	Detect	Observe	Recognize	Identify	2.8 mm	44.7 m (146.65 ft)	17.9 m (58.73 ft)	8.9 m (29.20 ft)	4.5 m (14.76 ft)	3.6 mm	55.0 m (180.45 ft)	22.0 m (72.18 ft)	11.0 m (36.09 ft)	5.5 m (18.04 ft)	6 mm	102.9 m (337.60 ft)	41.1 m (134.84 ft)	20.6 m (67.59 ft)	10.3 m (33.79 ft)
	Lens	Detect	Observe	Recognize	Identify																
	2.8 mm	44.7 m (146.65 ft)	17.9 m (58.73 ft)	8.9 m (29.20 ft)	4.5 m (14.76 ft)																
	3.6 mm	55.0 m (180.45 ft)	22.0 m (72.18 ft)	11.0 m (36.09 ft)	5.5 m (18.04 ft)																
6 mm	102.9 m (337.60 ft)	41.1 m (134.84 ft)	20.6 m (67.59 ft)	10.3 m (33.79 ft)																	
<p>*DORI (Detect, Observe, Recognize, Identify) is a standard system (EN-62676-4) for defining the ability of a person viewing the video to distinguish persons or objects within a covered area. The numbers in this table do not reflect intelligent function distances. For intelligent function distances, refer to installation and commissioning manual/project design tool.</p>																					

Video

Video Frame Rate	CVI: PAL: 1080p@25 fps NTSC: 1080p@30 fps AHD: PAL: 1080p@25 fps NTSC: 1080p@30 fps TVI: PAL: 1080p@25 fps NTSC: 1080p@30 fps CVBS: PAL: 960H NTSC: 960H
------------------	---

Resolution	1080p (1920 × 1080); 960H (960 × 576/960 × 480)
Day/Night	Auto(ICR)/Color/B/W
BLC	BLC; HLC; DWDR
WDR	DWDR
White Balance	Auto;Area white balance
Gain Control	Auto;Manual
Noise Reduction	2D NR
Illumination Mode	Smart IR&WL; WL Mode; IR Mode
Mirror	Yes
Privacy Masking	Off/On (8 areas, rectangle)

Certification

Certifications	CE-LVD: EN 62368-1; CE-EMC: EN 55032; EN 55035
----------------	---

Port

Video Output	Video output choices of CVI/TVI/AHD/CVBS by one BNC port
--------------	--

Power

Power Supply	12 VDC ± 30%
Power Consumption	Max 3.3 W (12 VDC, LED on)

Environment

Operating Temperature	–40 °C to +60 °C (–40 °F to +140 °F)
Operating Humidity	<95% (RH), non-condensing
Storage Temperature	–40 °C to +60 °C (–40 °F to +140 °F)
Storage Humidity	<95% (RH), non-condensing
Protection	IP67
Anti-corrosion Level	Basic Protection

Structure

Casing Material	Metal
Product Dimensions	150.0 mm × 69.7 mm × 70.0 mm (5.91" × 2.74" × 2.76")
Net Weight	0.27 kg (0.60 lb)
Gross Weight	0.33 kg (0.73 lb)
Installation	Wall mount; ceiling mount; vertical pole mount

Ordering Information		
Type	Model	Description
2MP Camera	DH-HAC-B2A21P-U-IL	2MP Smart Dual Light HDCVI Fixed-focal Bullet Camera, PAL
	DH-HAC-B2A21N-U-IL	2MP Smart Dual Light HDCVI Fixed-focal Bullet Camera, NTSC
Accessories (Optional)	PFA134	Junction Box
	PFA130-E	Water-proof Junction Box
	PFA152-E	Pole Mount Bracket
	PFM321D	12V 1A Power Adapter
	PFM800-E	Passive HDCVI Balun
	PFM904	Integrated Mount Tester

Dimensions (mm[inch])

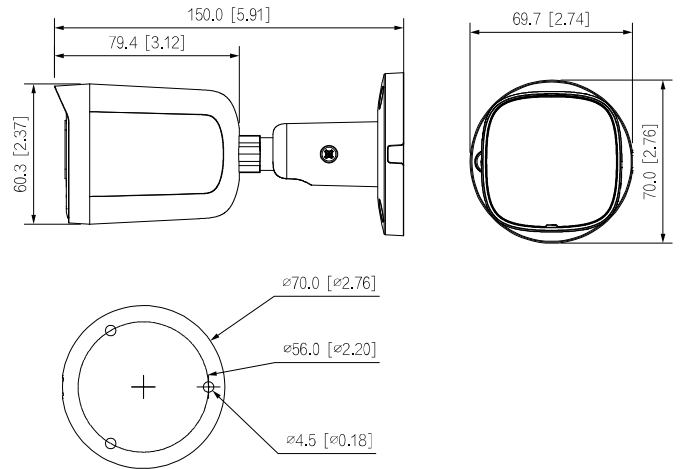

Accessories

Optional:



PFA134
Junction Box



PFA130-E
Water-proof Junction Box



PFA152-E
Pole Mount Bracket



PFM321D
12V 1A Power
Adapter



PFM800-E
Passive HDCVI Balun



PFM904
Integrated Mount Tester

Ceiling Mount	Junction Mount	Pole Mount(Vertical)